



Advancing timber fabrications through design : components : manufacture

[www.itwalpine.co.uk](http://www.itwalpine.co.uk)

MCL

T-GL

005



# Trussed Rafter Guide

# Contents

## THE ITW ALPINE SYSTEM..... 03

## CONSTRUCTION DETAILS..... 04

Valley Construction..... 04

Loose Hip..... 04

Hip End Construction - Standard..... 05

Hip End Construction - Multiple Girders..... 06

Barn Hip Construction..... 07

Part or Bonnet Hip Construction..... 07

Hip Corner Construction..... 08

Scissors Construction..... 10

Raised Tie Construction..... 10

Dog Leg Intersection..... 11

## TRIMMING DETAILS..... 12

Room in the Roof - Roof Light..... 12

Room in the Roof - Staircase..... 12

Chimney & Trap Hatch Trimming..... 13

## GABLE DETAILS..... 14

Gable Wall Restraining Straps..... 14

Party Wall Restraining Straps..... 15

Gable Ladders..... 15

## BRACING DETAILS..... 16

Bracing Types..... 16

Raised Tie Bracing..... 17

Room in the Roof Bracing..... 18

British Standard Bracing - Duo Pitch..... 19

British Standard Bracing - Mono Pitch..... 20

## WATER TANK DETAILS..... 21

Water Tank Support Detail..... 21

## GLOSSARY OF TERMS..... 22

# ITWALPINE

## Advancing Timber Frame Fabrication

ITW is a leading international business corporation with revenues in excess of \$US14 billion and almost 100 years of experience in the design, development & manufacture of fasteners & components and equipment & consumable systems, as well as a variety of speciality products for customers all around the world.

ITW's financial performance is generated by some 825 decentralised business units, employing over 60,000 people in 52 countries. Typically amongst the top 100 patent holders in the USA, ITW holds over 5,000 product lines. Ranked 257th in the FT's global list of the worlds largest companies ahead of household names such as Colgate - Palmolive, Oracle and Heinz, ITW is well positioned to meet the challenges of today's global markets.



ITW Alpine is a member of the Trussed Rafter Association

# The ITW Alpine System

## QUALITY OF PRODUCT

ITW Alpine trussed rafters are manufactured from softwoods strength graded in accordance with either BS4978, BSEN518, BSEN519 or as recommended in BS5268 : Part 2 and punched metal plate timber fasteners which have been fully tested and certified by UK Accreditation Authorities.

All trussed rafter designs are prepared in full accord with the relevant British Standard Codes of Practice, notably BS5268 Parts 2 and 3 in the UK and NASI Standard IS193 in Eire. Designs also fully meet the requirements of the current statutory Building Regulations.

Timber for trussed rafters may be protected against biological degradation and insect attack by the use of preservative pre-treatment. Advice should be sought from the truss suppliers regarding suitable forms of treatment.

## TECHNICAL SUPPORT

An extensive suite of roof design and trussed rafter engineering software is available at all ITW Alpine system fabricators across the UK & Eire enabling them to provide highly developed designs for almost any truss configuration and which, if required, will also prepare comprehensive roof layout drawings and details according to the exact requirements of individual projects. These fabricator services are further enhanced by the resources of a specialist roof design department, at ITW Alpine's head office in Truro to give advice on any aspect of trussed roofs and associated components.

## COST REDUCTIONS

Trussed rafter roofs provide more economic solutions than traditional methods for the following reasons:

- Roof structures are erected quickly.
- Trusses are generally spaced at 600mm centres giving economy in the use of timber.
- Erection procedure is simple and repetitive, requiring only a minimum of skilled labour.
- Architects and developers have a free rein in forming economic roofscapes.
- Standard designs require only external walls to be load-bearing, thereby eliminating intermediate supports.
- Waste and pilferage are minimized.
- Programmed deliveries to suit construction schedules reduce handling and storage costs.

*The trussed rafter details in this brochure are generated by ITW Alpine's engineering software "VIEW"*



# Valley Construction

The construction of valleys using prefabricated reducing valley trusses allows the formation of roof intersections with minimum of site-cut infill. The valley trusses are aligned and the topmost braced back to the supporting trusses; diagonal bracing is then fixed and a longitudinal tie at the apex node. Ideally, the lower edge of the bottom chord of the valley frames is bevelled to suit the roof slope of the supporting trusses or fixing thrust battens cut from one piece of timber for economy. Sarking, tiling battens and tiling can then be carried out to line in with the supporting roof.

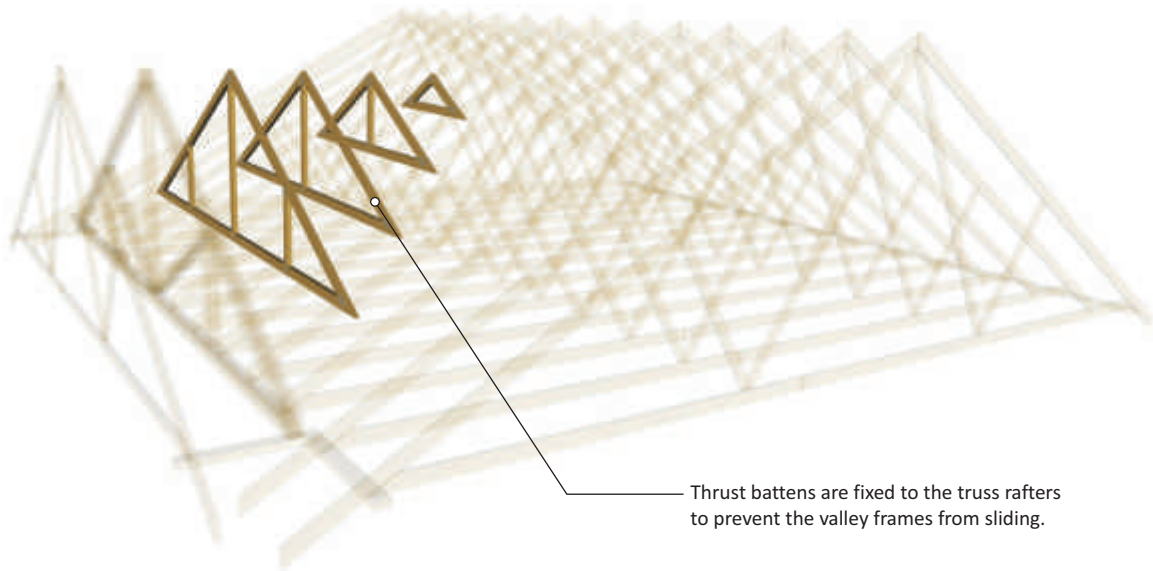

# Loose Hip Construction

For spans up to 5.7m overall wall plates, a completely loose timber infill can be supported by a girder truss positioned at half the span from the end wall.

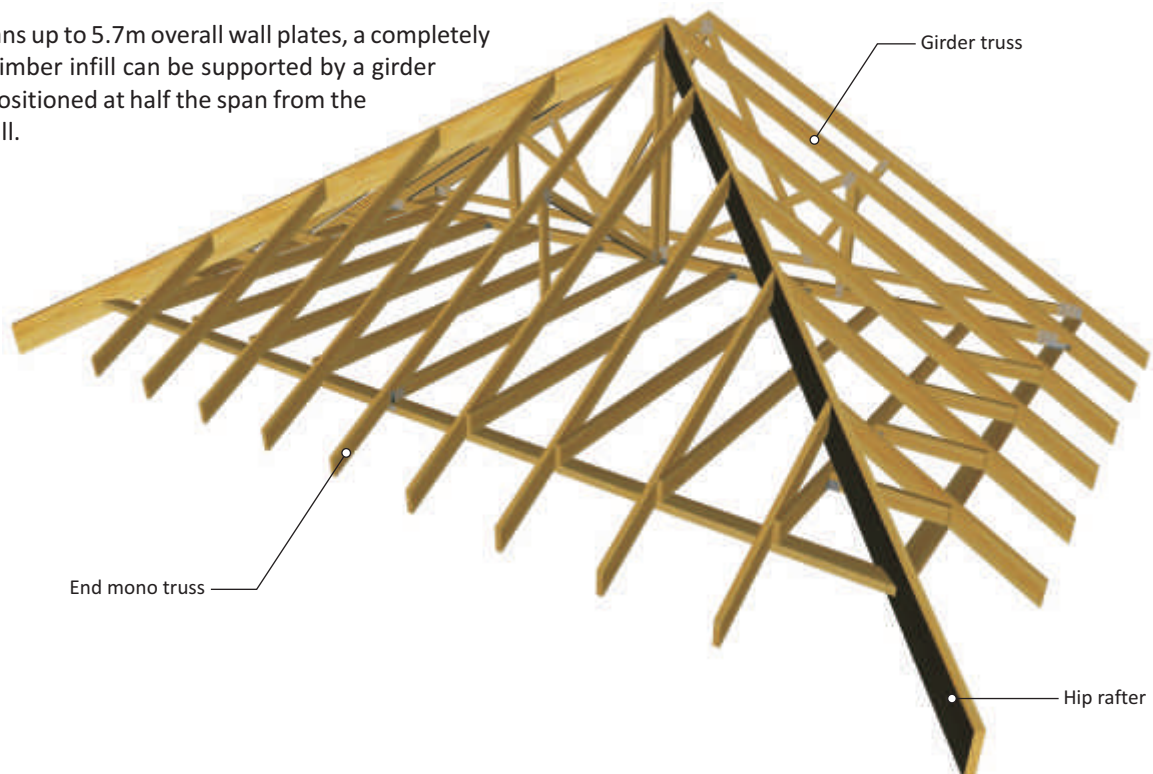

# Hip End Construction - Standard

The design has evolved to reduce traditional infill at hipped ends to a minimum - thereby keeping site material and labour costs down.

The main structural components consist of a multi-ply hip girder which supports the mono pitch trusses and hip rafters forming the hip.

Single hip girders are then used to infill up to the first full truss at the end of the ridge, generally at the same spacing as the full trusses for economic use of components. The mono-pitch trusses and the single hip girder trusses may be supplied with extended rafters for site fixing to the hip rafter.

Alternatively, the extension rafters may be omitted to allow for site fixing of loose, pre-cut jack rafters.

Truss shoes are used for supporting the mono pitch trusses on the hip girder truss.

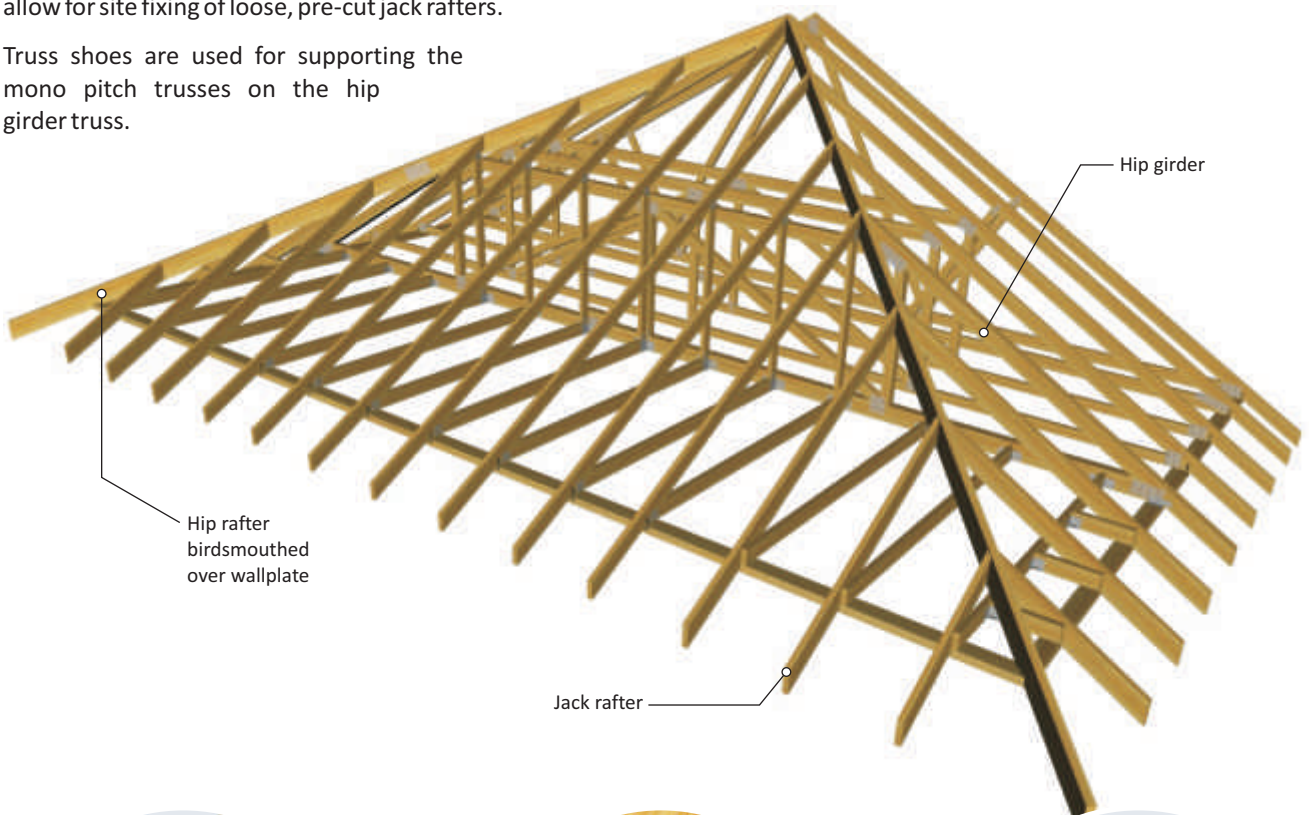
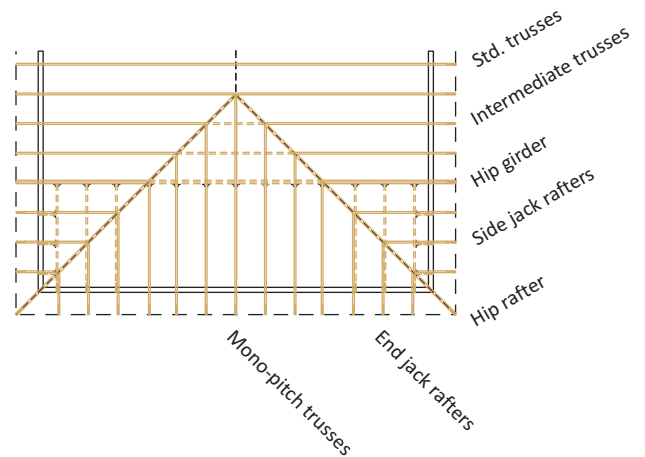

**Hipboard / Haunch**  
(Hip rafter birdsmouthed over girder top chord)

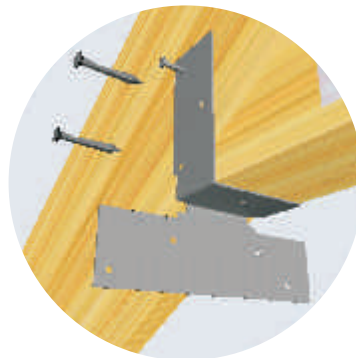

**Standard truss clip**  
(wallplate omitted)

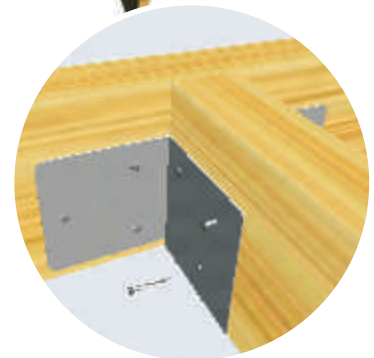

**Truss shoe supporting monos & loose ceilings joists**  
(all nail holes used with 3.75 x 30mm square twisted nails )

# Hip End Construction - Multiple Girders

Similar to the Standard Hip End in basic concept, this method is suitable for larger spans, up to about 15m. Two or more multi-ply girders are used, with flat top infill trusses in between, to maintain the standard truss spacing.

The mono pitch rafter extensions/jack rafters are economically designed to suit the truss rafter size, and are supported as specified by posts from the substructure.

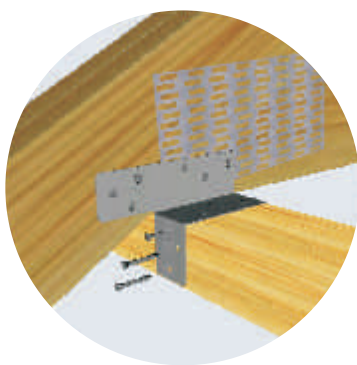
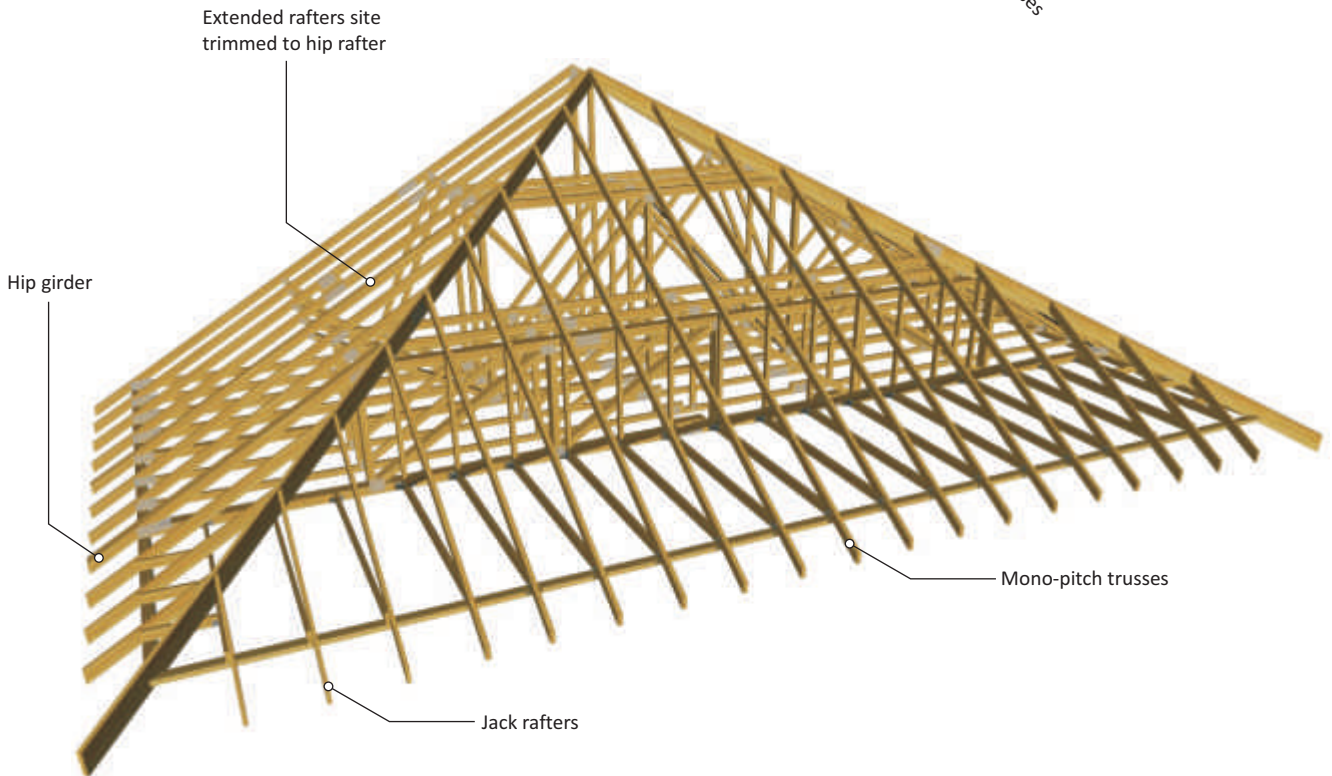
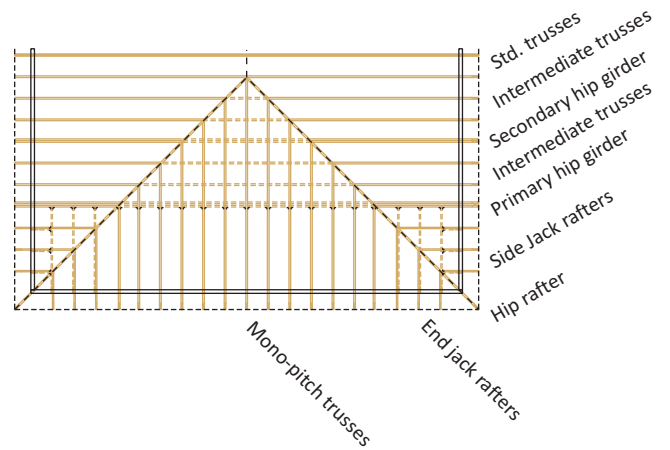

**Framing anchor fixed each side of the girder trusses**  
(all nails holes used with 3.75 x 30mm square twisted nails)

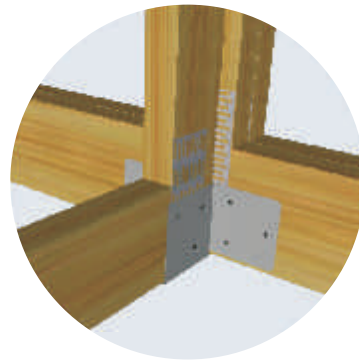

**Truss shoe supporting monos & loose ceilings joists**  
(all nail holes used with 3.75 x 30mm square twisted nails)

# Barn Hip Construction

This form of hipped end takes its name from the traditional barn roof, wherein the gable end is built up above the wall plate line, but terminates below the ridge position. A part-hip is thereby formed.

To accommodate this roof shape, flat-top trusses are used over the length of the part-hip, with the usual hip rafter incorporated to complete the roof line.

No girder or multi-ply trusses are required in the construction as the standard spacing of truss components continues to the gable end.

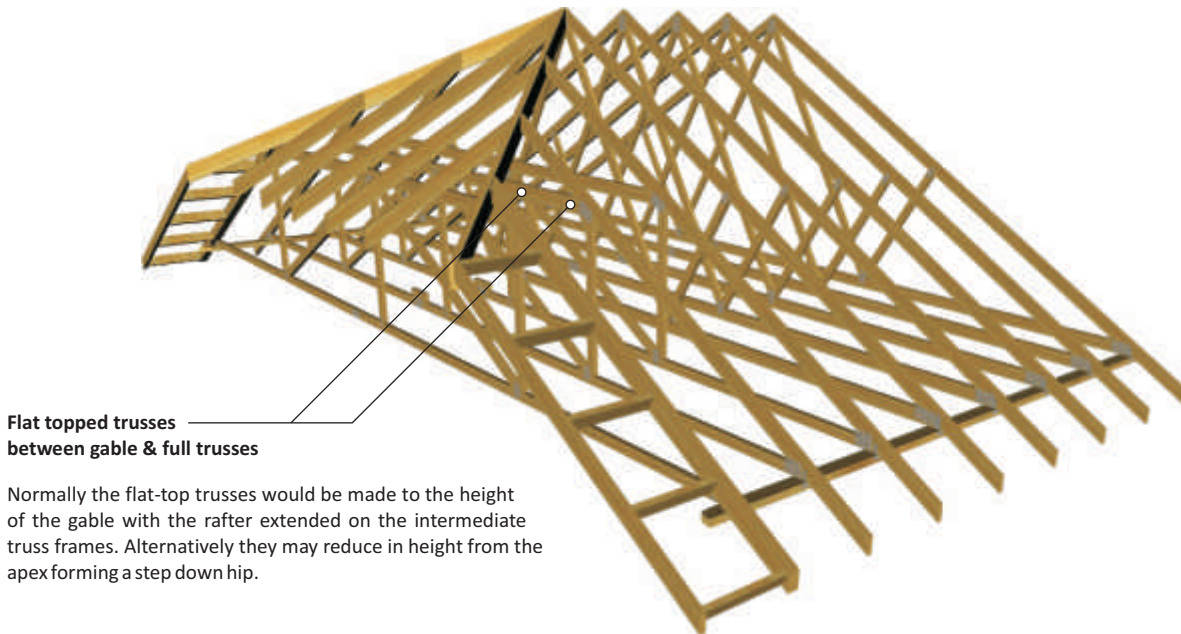

# Part or Bonnet Hip Construction

This variation to a normal hip end depicts a rural style termination at the end of the ridge, exposing a vertical triangle above the normal hipped end. The construction is very simple, using a compound truss at the "bonnet" position with the mono-pitch trusses supported from this compound. The hip rafters would be cut and positioned as for normal hipped ends.

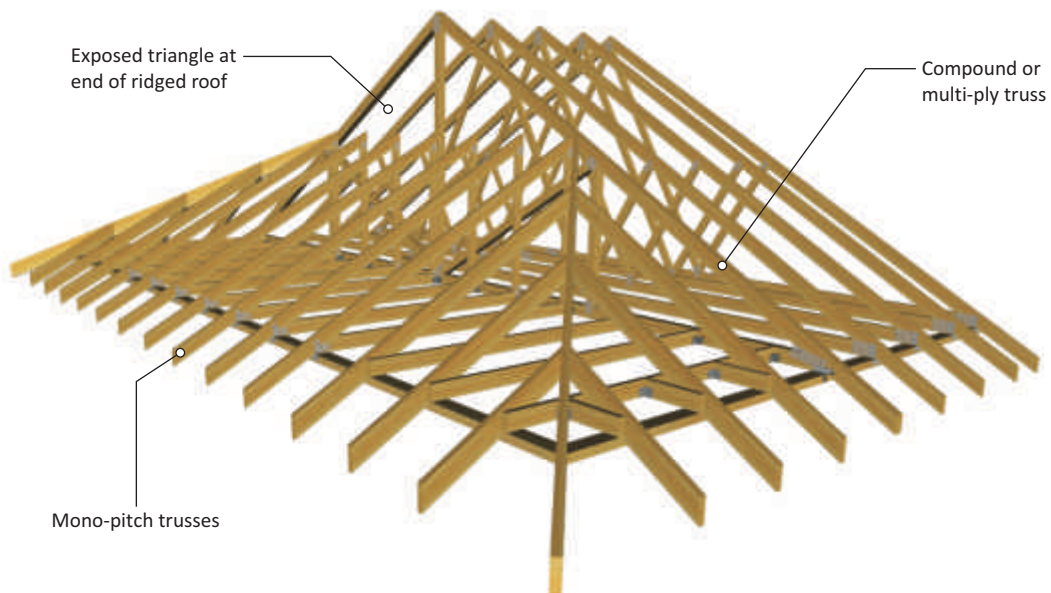

# Hip Corner Construction

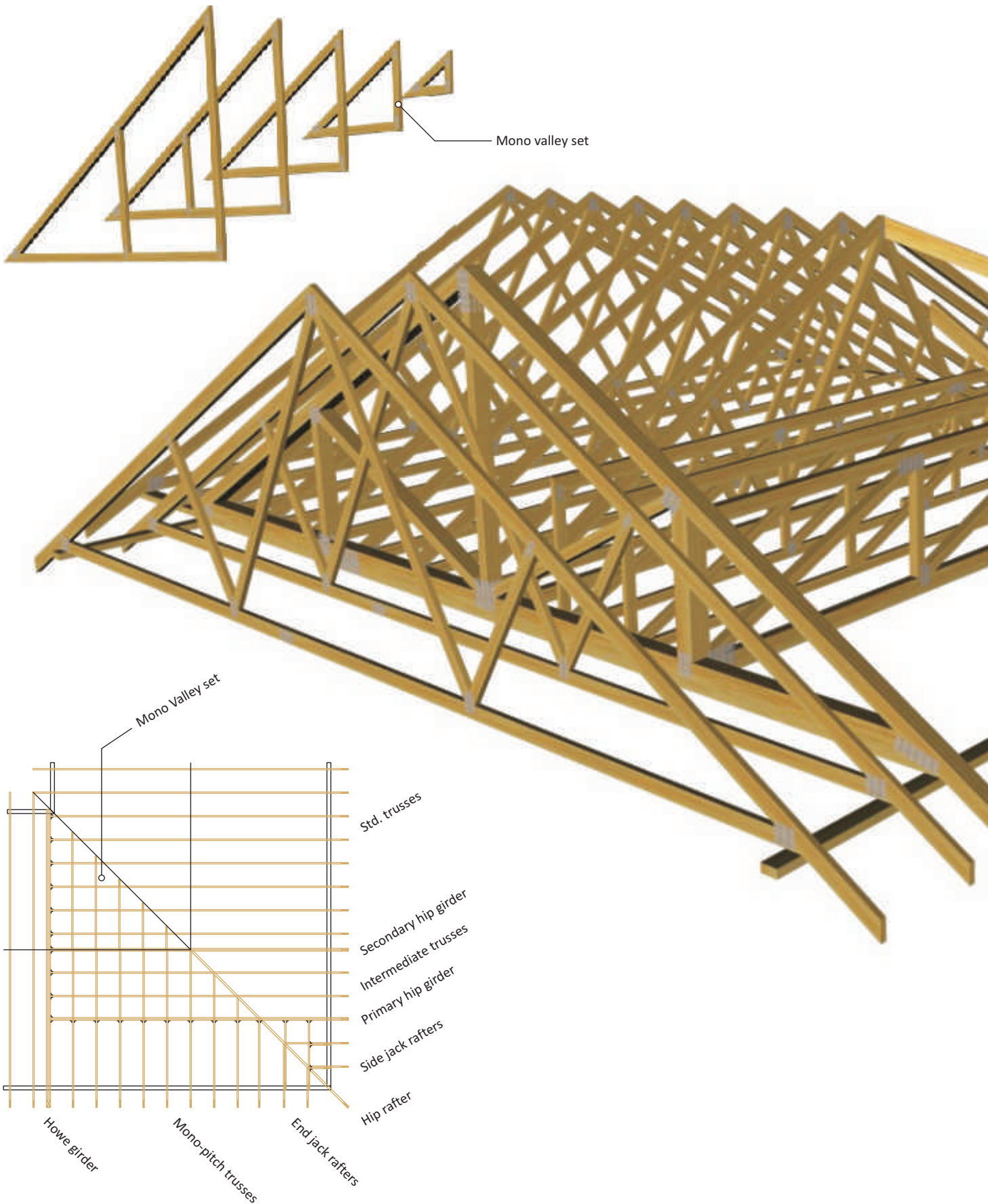



Hip corners are formed in a similar way to the other hips but with a Howe girder truss to support one end of the hip trusses.

The Howe girder truss may not be required if a load bearing wall lines through with the wallplate of the main roof.

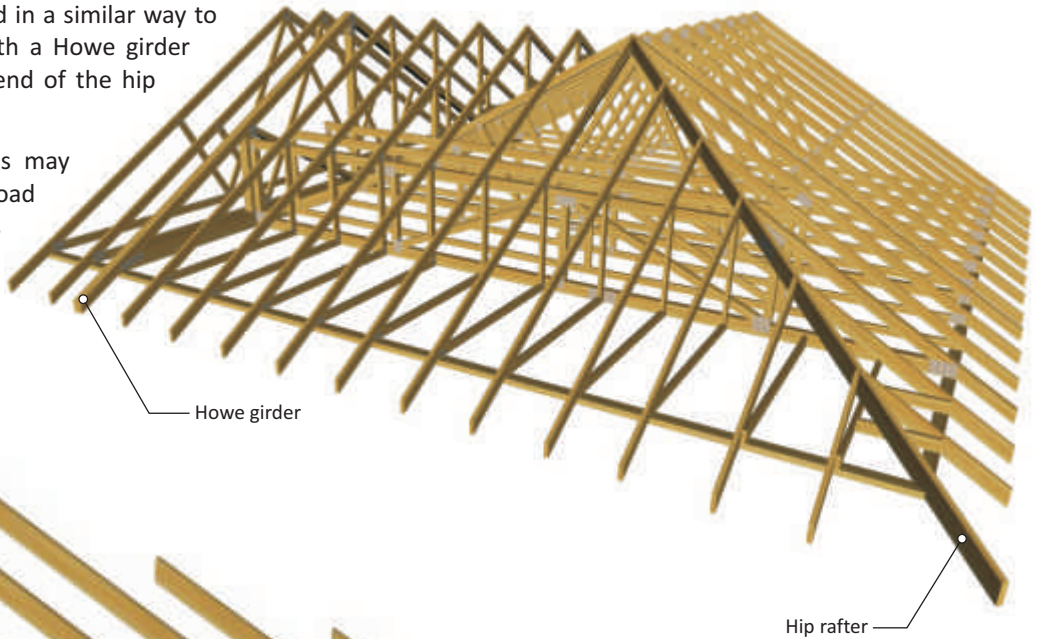

Howe girder

Hip rafter

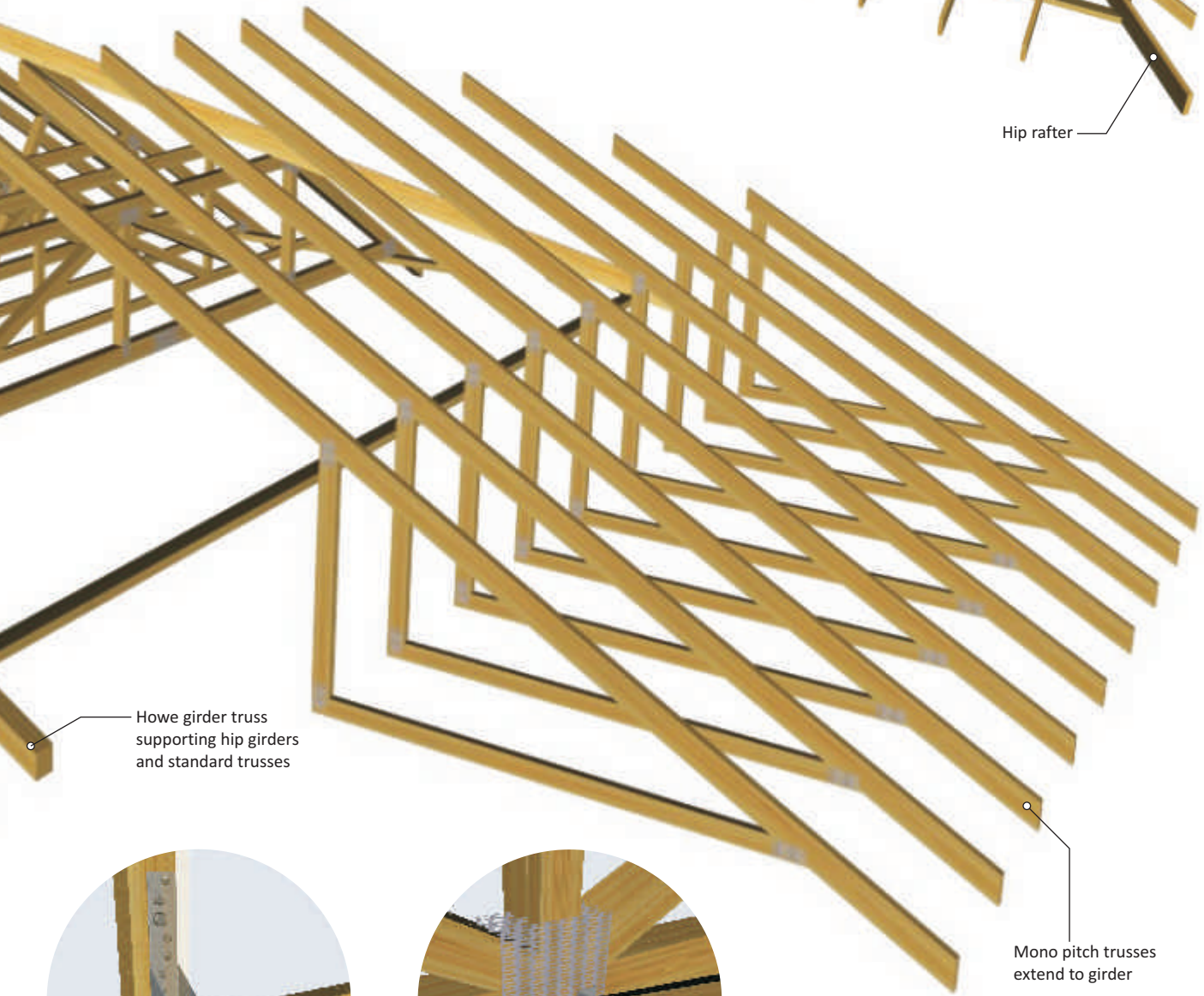

Howe girder truss supporting hip girders and standard trusses

Mono pitch trusses extend to girder

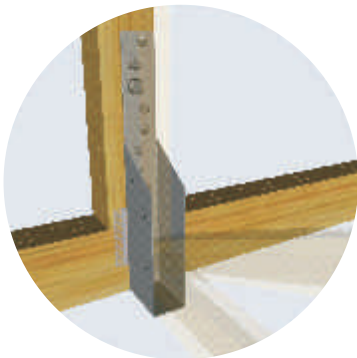

Principal truss shoe supporting primary hip girder

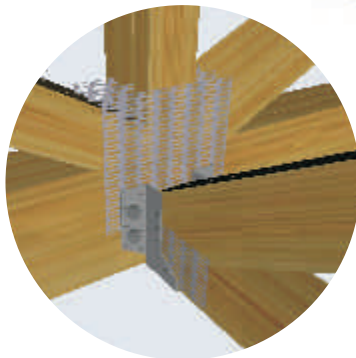

Heavy duty truss shoe supporting secondary hip girder

# Scissors Construction

Due to the elevation of the bottom chord, some degree of horizontal movement or force will be generated at wallplate levels. Research into normal domestic masonry wall construction has shown that up to 12mm of total deflection can be tolerated by the walls. Designs are therefore constrained by this limitation. The use of ITW Alpine glide shoes, which allows reasonable horizontal movement across the walls without imposing horizontal thrust, assists in accommodating horizontal deflection. Building Designers should carefully consider any wall restraint required when using Scissor or Raised Tie trusses.

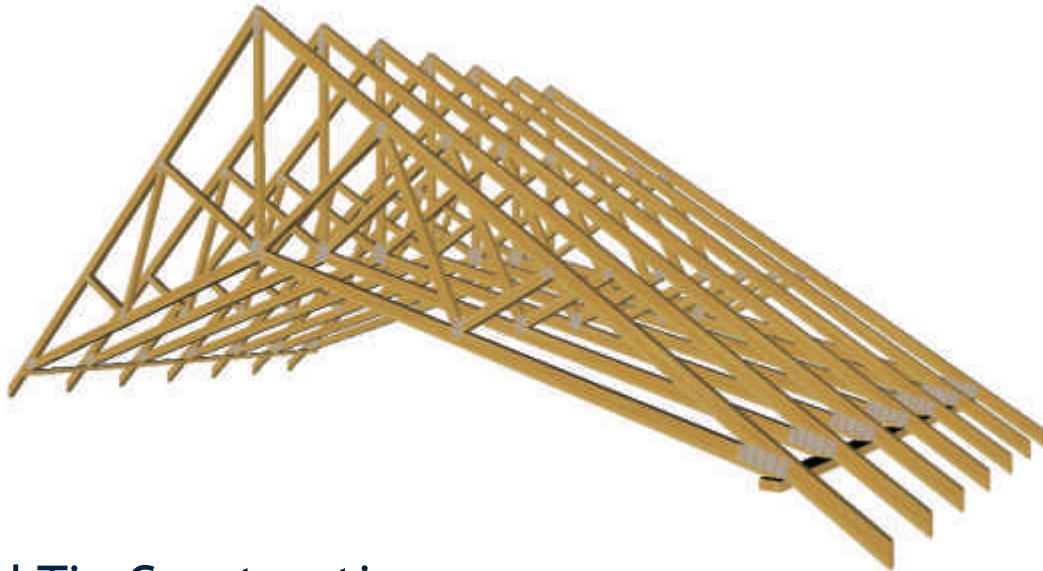

# Raised Tie Construction

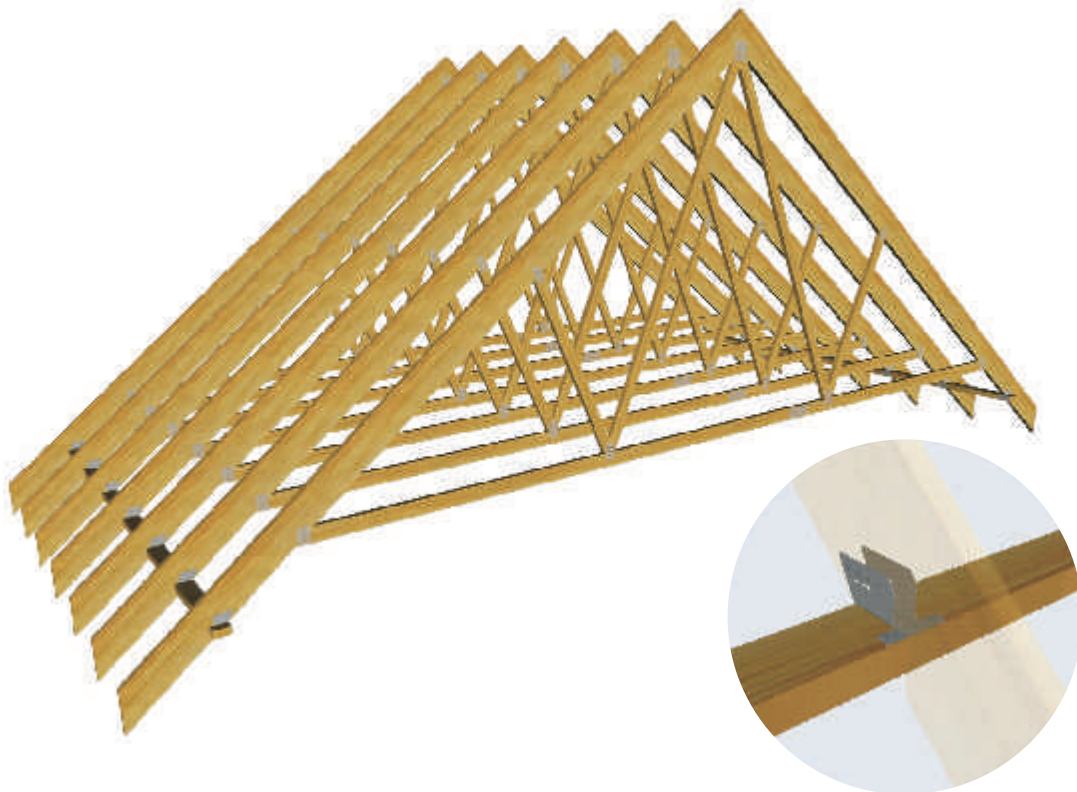

**TW964 Glide shoe**  
(all nails holes used with 3.75 x 30mm square twisted nails )

# Dog Leg Intersection

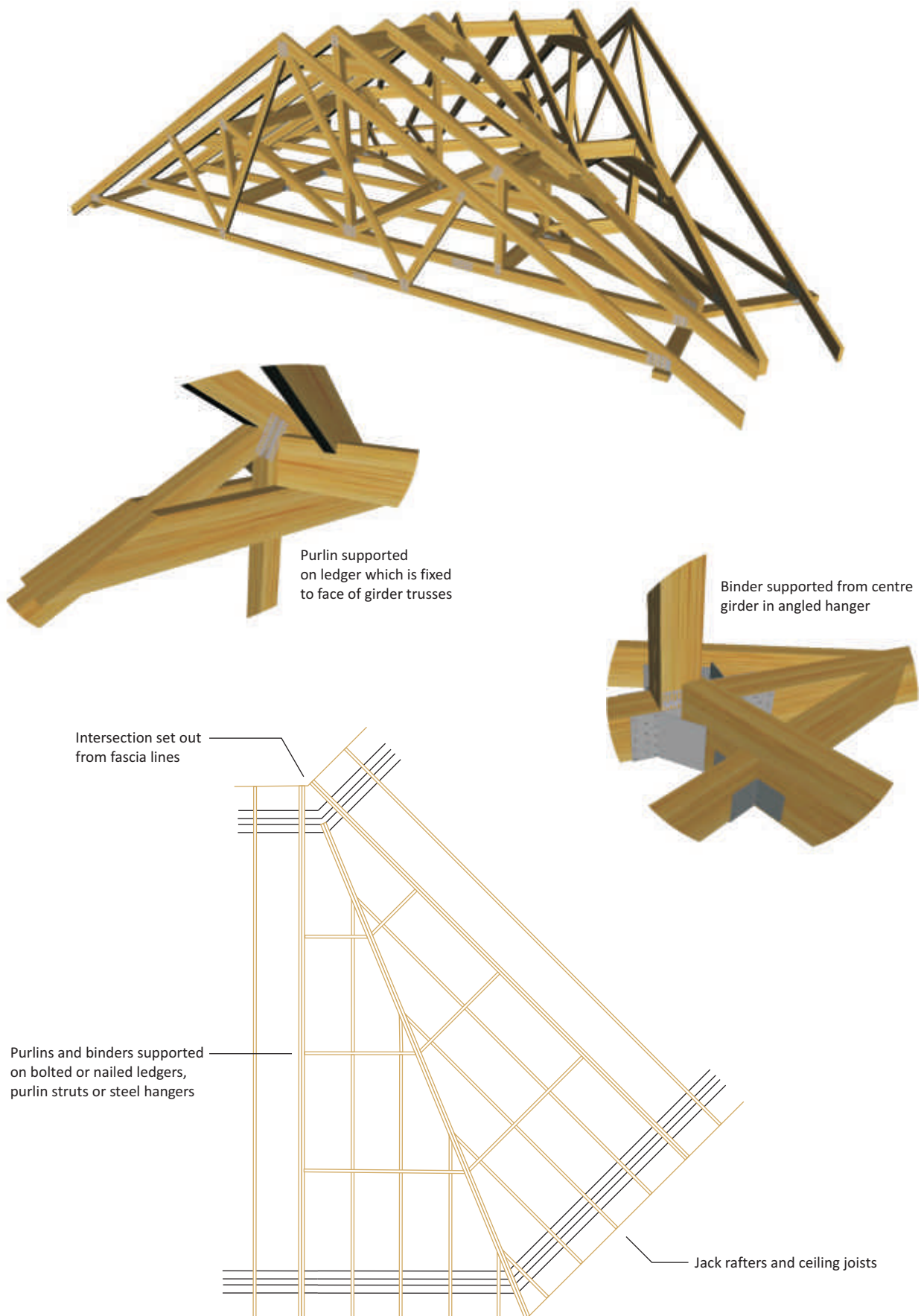

## Room in the Roof - Roof Light

For normal roof spans, up to around 9m and larger spans with internal load bearing walls the truss members can be economically designed to carry domestic loading.

For typical dormer windows, traditional purlins supported on multi-ply trusses carry the intermediate infilling over the dormer.

The rafters and extension ceiling ties are nailed on, to form the flat roof over the dormer window.

For larger spans and those with intensive trimmed openings, latticed purlin beams are required. These are supported on end and transverse walls and provide maximum floor space.

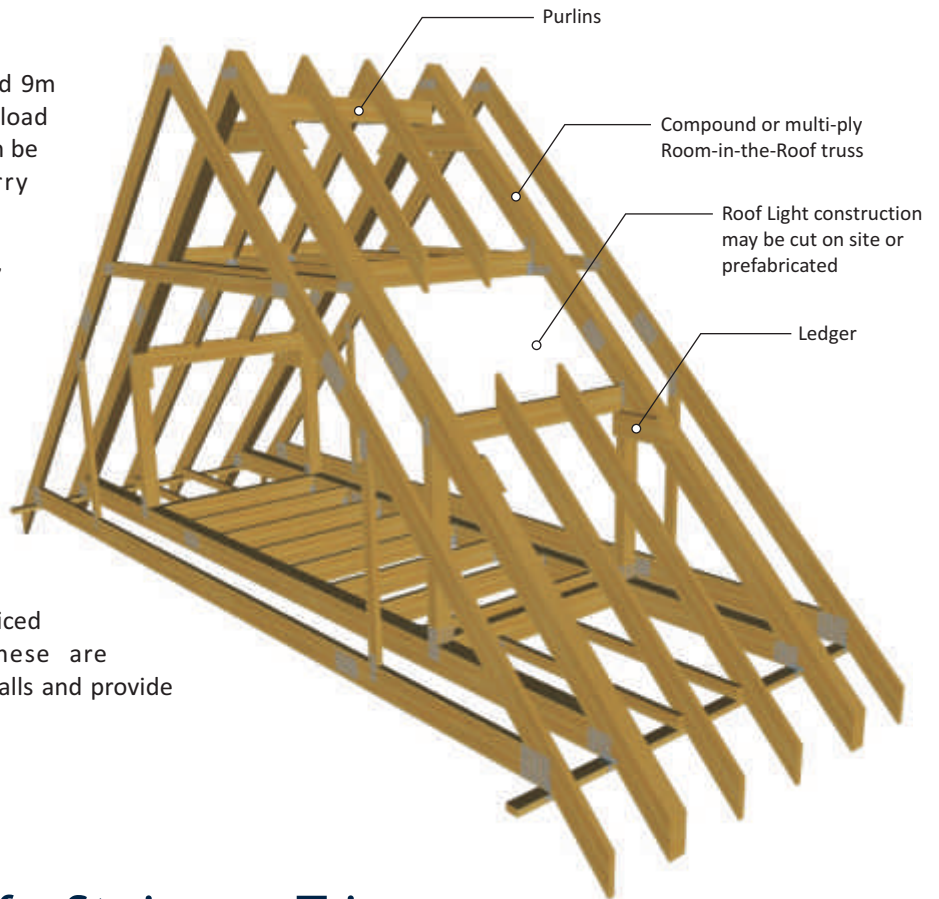

## Room in the Roof - Staircase Trim

For stairwells, multi-ply trusses or support walls are required each side of the opening and binders are fixed as required to support the floor joists and roof infill. The staircase opening should then be trimmed in the traditional manner.

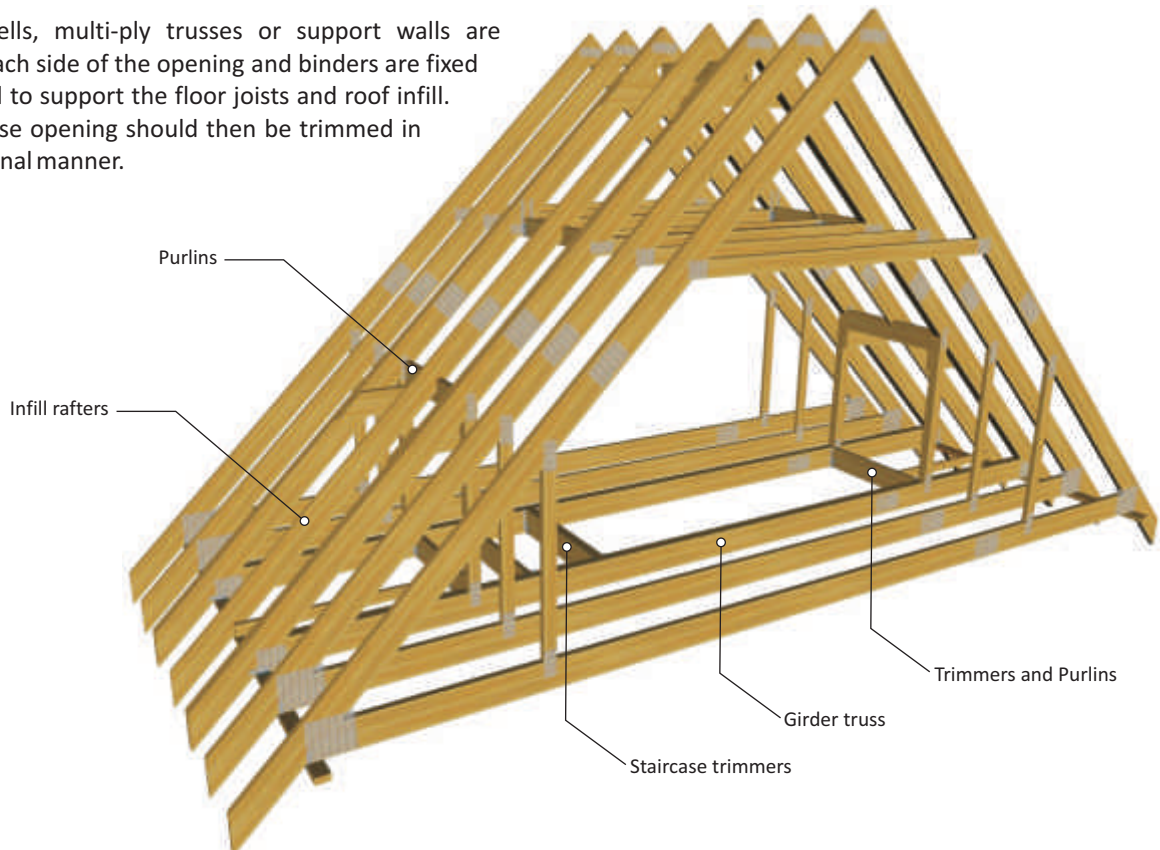

# Chimney & Trap Hatch Trimming

Small chimneys and hatches may be accommodated within the standard truss spacing. Progressive details are used to accommodate chimney and hatches up to twice the standard truss spacing.

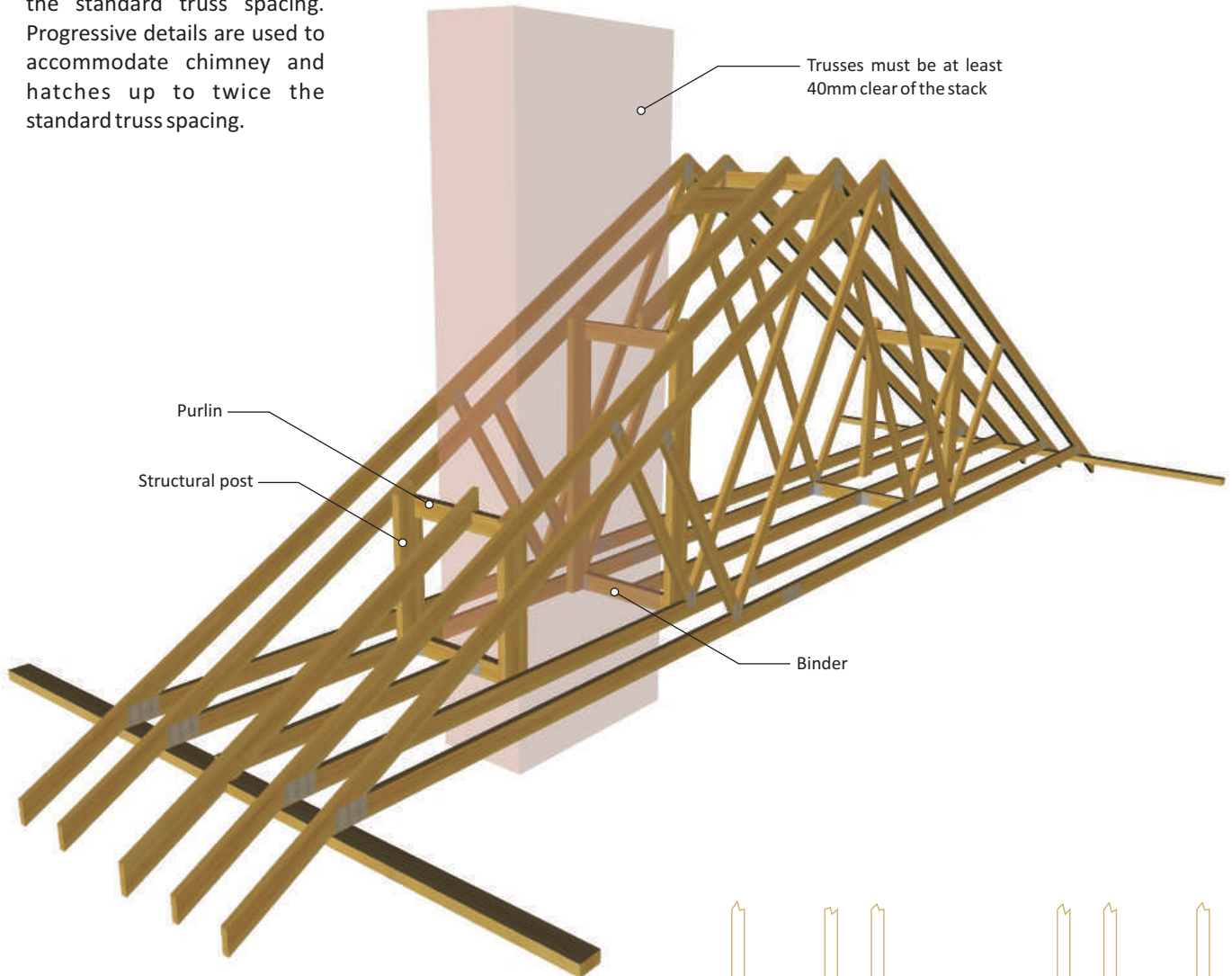

**Trap hatch detail**  
(rafters / webs omitted for clarity)

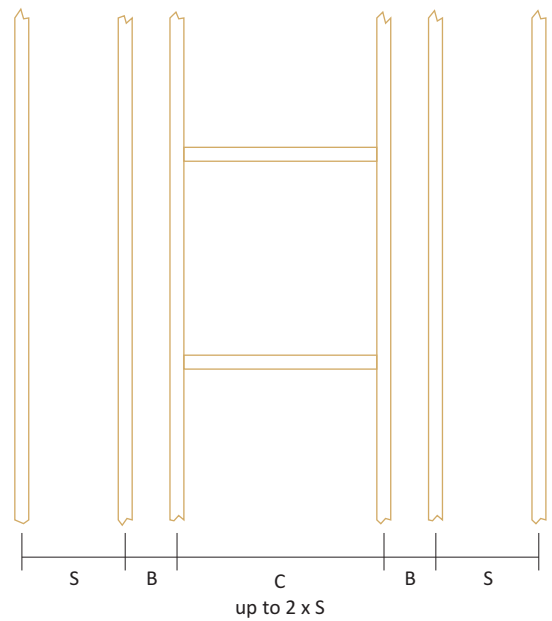

B must be not more than  $2S - C$  where S is the standard spacing.

# Gable Wall Restraining Straps

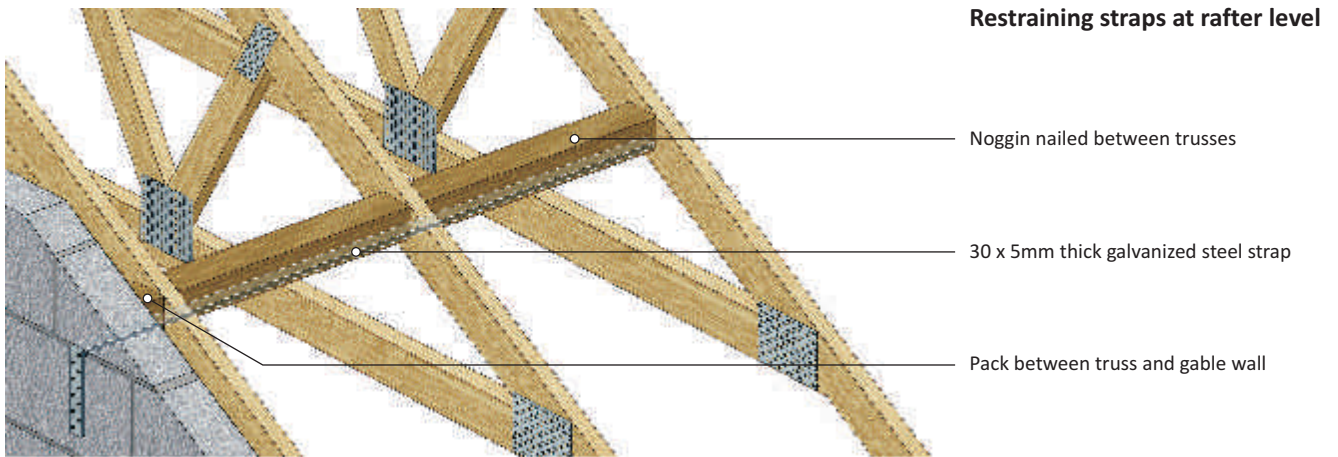

Restraining straps must be installed to transmit wind loads on walls into the roof structure, and give stability to the walls.

In the absence of any specific guidance from the building designer, connections should be made with 30 x 5mm thick galvanized steel straps fixed to at least three trusses and noggins with 3.35 x 50mm long galvanized wire nails as shown. On gable walls they should be spaced at not more than 2m centres at rafter and ceiling joist level.

## Restraining straps at ceiling joist level

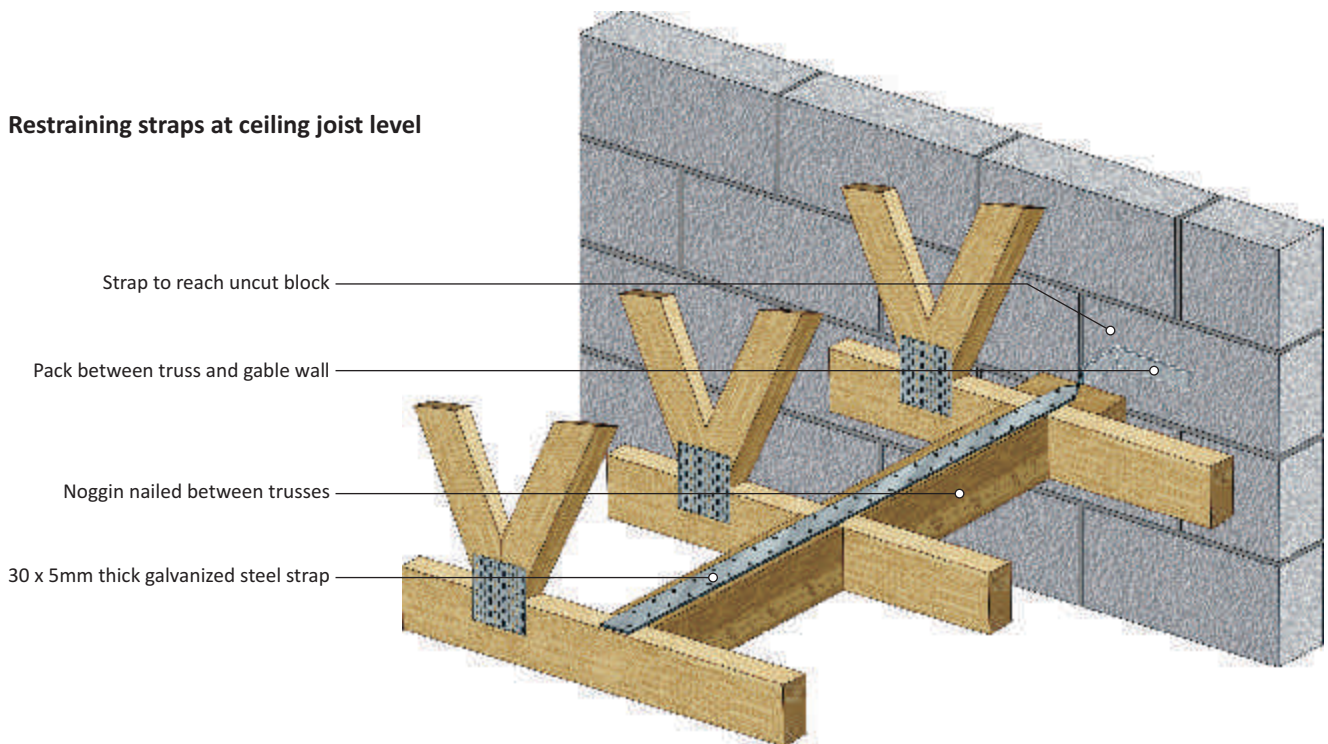

# Party Wall Restraining Straps

Restraining straps must be installed to transmit longitudinal bracing forces along the roof structure and to give stability to the walls. In the absence of any specific guidance from the building designer, connections should be made with 30 x 5mm thick galvanized steel straps fixed to at least three trusses and noggins with 3.35 x 50mm long galvanized wire nails as shown. Party walls should have restraining straps at ceiling tie levels spaced at not more than 2m centres, with the strap connected to three or more trusses on each side of the wall. Straps may also be required at rafter level to transmit longitudinal bracing forces.

Party walls should be stopped 25mm below the tops of rafters. Layers of non-combustible compressible fill such as 50mm mineral wool should be placed above party wall to provide a fire stop.

If the tiling battens are required to be discontinued over a party wall, then lateral restraint must be provided in addition to that required to transfer longitudinal bracing forces. This should consist of straps (or equivalent) adequately protected against corrosion, with a minimum cross sectional area of 50sq. mm. These straps should be spaced at not more than 1.5m centres, and be fixed to three rafter members and noggins on each side of the party wall by 3.35mm diameter galvanized nails with a minimum penetration into the timber of 32mm.

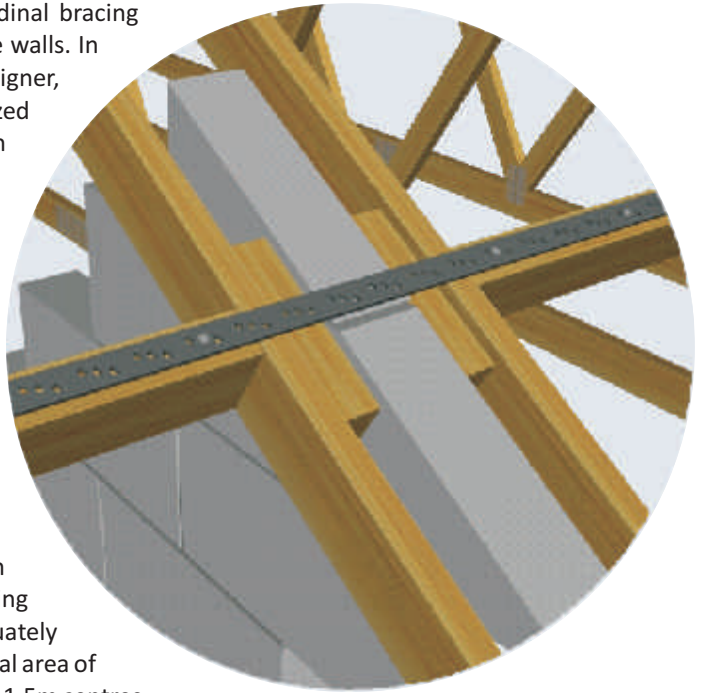

Before using this detail the Building Designer should satisfy themselves that it meets the requirements of all regulatory bodies concerned with the project.

# Gable Ladders

Barge boards & soffits are nailed directly onto the gable ladder

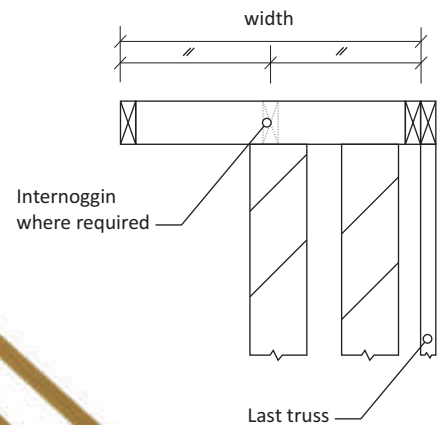
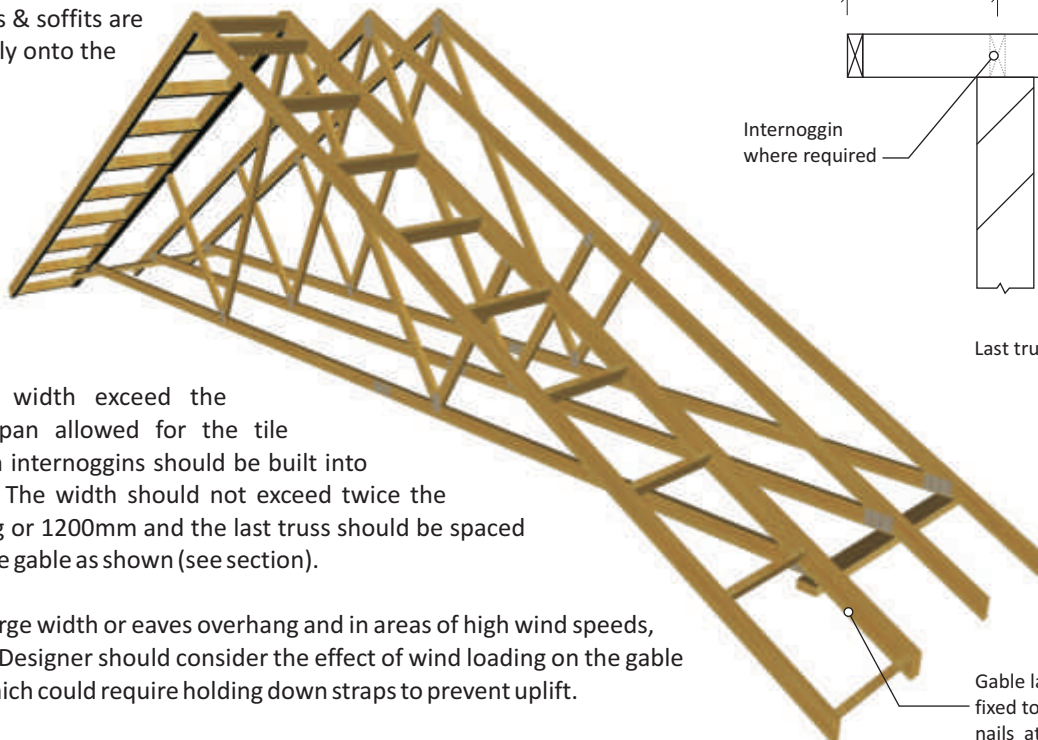

Should the width exceed the maximum span allowed for the tile battens then internoggins should be built into the ladder. The width should not exceed twice the truss spacing or 1200mm and the last truss should be spaced back from the gable as shown (see section).

In cases of large width or eaves overhang and in areas of high wind speeds, the Building Designer should consider the effect of wind loading on the gable overhang which could require holding down straps to prevent uplift.

# Bracing Types

Permanent bracing can be constructed from either solid timber (minimum size 22 x 97mm or 38 x 89mm), or a suitable sheathing material (sarking). BS5268 : Part 3 states that bracing timbers should be free of major strength reducing defects. Timber bracing should be fixed using two 3.35mm diameter galvanized round wire nails at each crossover point. The length of the nails should be 65mm for 22/25mm bracing & 75mm for 38mm bracing. The main types of bracing include :-

## Rafter Diagonal Bracing

(RD). This is bracing fixed to the underside of the rafter. It provides lateral stability to the roof structure and in conjunction with the total roof diaphragm, transfers wind loads to shear resisting walls.

## Longitudinal Bracing

(LR/LT/LTB). This is bracing fixed at each joint excluding support locations. It acts in conjunction with the rafter diagonal bracing to provide lateral stability to the roof structure and provides essential stability at the truss nodes for use in the structural analysis.

## Chevron Bracing

(CB). This is diagonal bracing fixed to internal members. It provides additional stability to the complete roof system. Such bracing is required on duo-pitch roof profiles in excess of 8m and for mono-pitch roof profiles in excess of 5m.

## Restraining Battens

(RB). These are longitudinal braces fixed to web members to provide lateral restraint to those members (where required from truss calculations).

The Building Designer should note that the bracing shown, which is in accordance with Annex A of BS5268 part 3, only provides stability for the trusses. If additional restraint is required for the walls then specially designed bracing will need to be provided. Typical examples of this are long unbuttressed lengths of masonry walls or high walls. There is guidance given on limiting dimensions in Part A of the Building Regulations, or the walls may be designed in accordance with BS5628. The maximum truss spacing is 600mm, and plasterboard or some other equivalent ceiling material should be used. It is essential that these important construction details, among others, are considered carefully during the building design process.

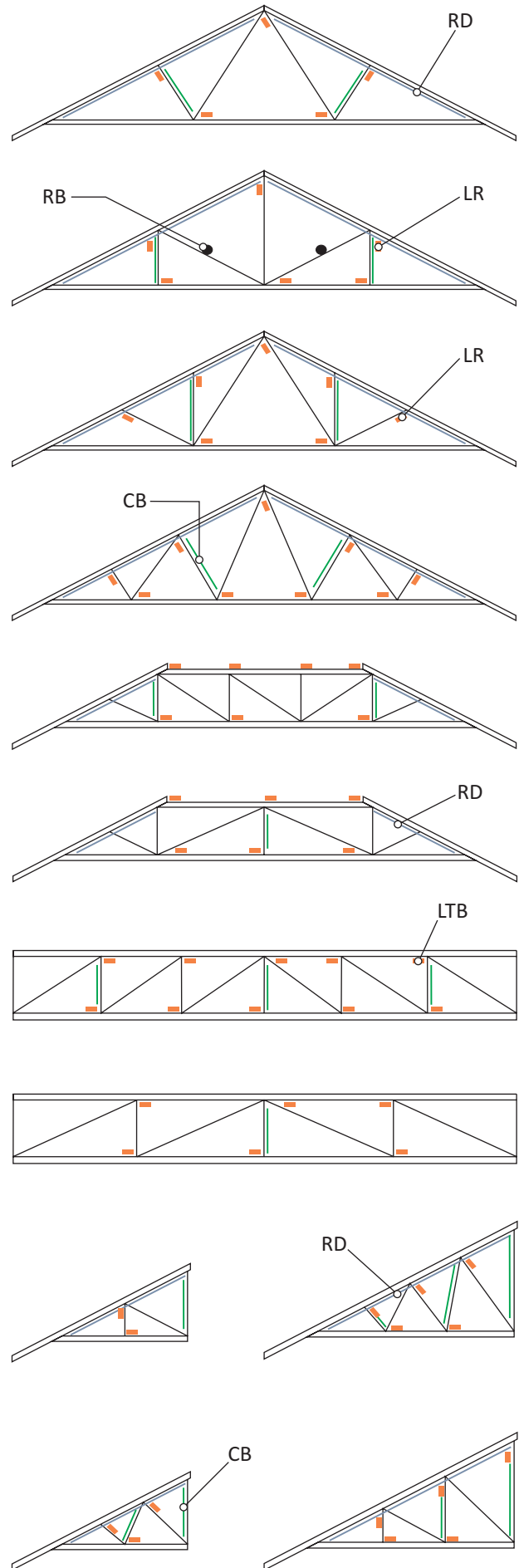



# Raised Tie Bracing

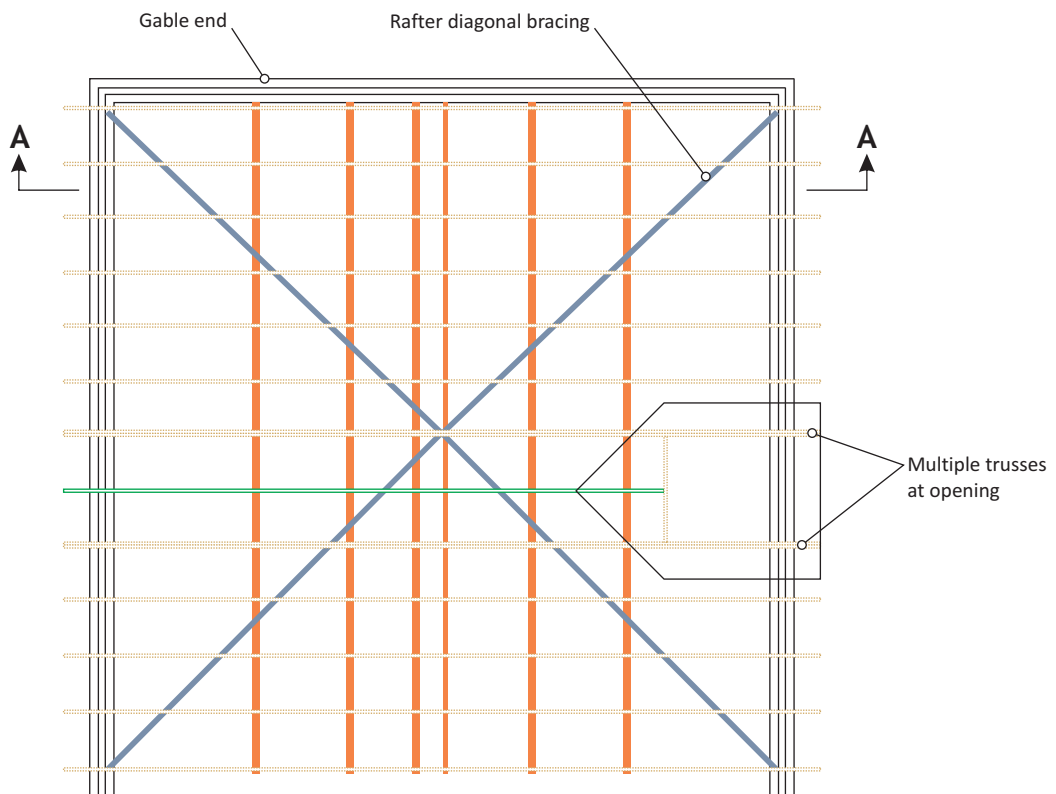
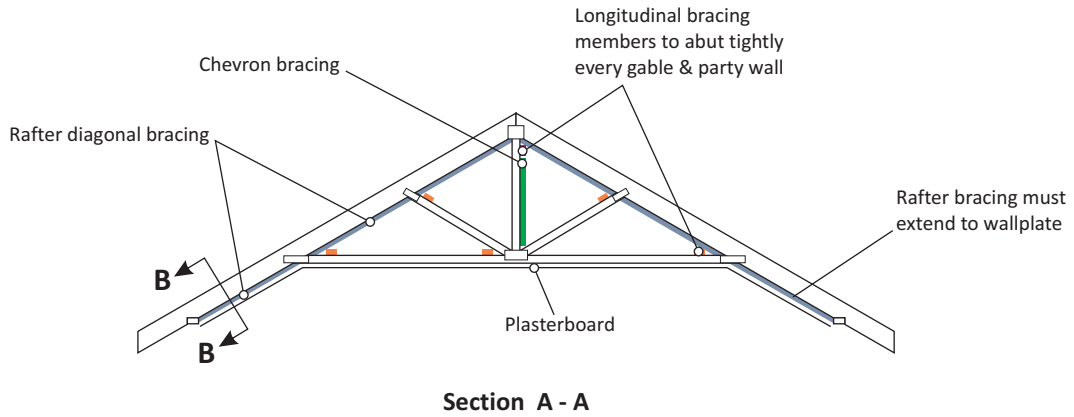

Permanent stability bracing should be installed in accordance with the design drawings.

Rafter diagonal bracing should extend to contact the wallplate. This may be timber or suitable rigid sarking.

Where the design drawings show either plywood bracing or rigid sarking to the upper surface of the rafters, ensure that it is fixed as specified.

In all roofs using raised tie trusses, fix plasterboard, sheathing or an equivalent diaphragm to the ceiling tie and extended rafters.

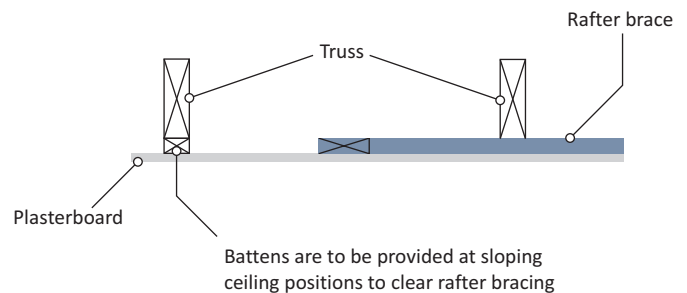

**Section B - B**  
(detail where timber brace is used under rafter extension)

# Room in the Roof Bracing

To comply with Building Regulation the floor area should be strutted out in between the joists. Two methods are commonly in use: 1 - Herring bone strutting can be used where the truss spacing is less than 3 times the joist depth & consists of a cross of 38 x 38mm timber cut tightly to the face & skew nailed into position, 2 - Solid strutting may be used in all situations & consists of 38 x 0.75 depth of joist. The timber must be a good fit, nailed top & bottom.

For attic rooms less than 2500mm strutting is not required, between 2501 & 4500 use one row positioned mid span. Between 4501 & 5500 use 2 rows at third span positions. When the room width exceeds 5501 install as many rows as necessary so that the spacing is not greater than 2250.

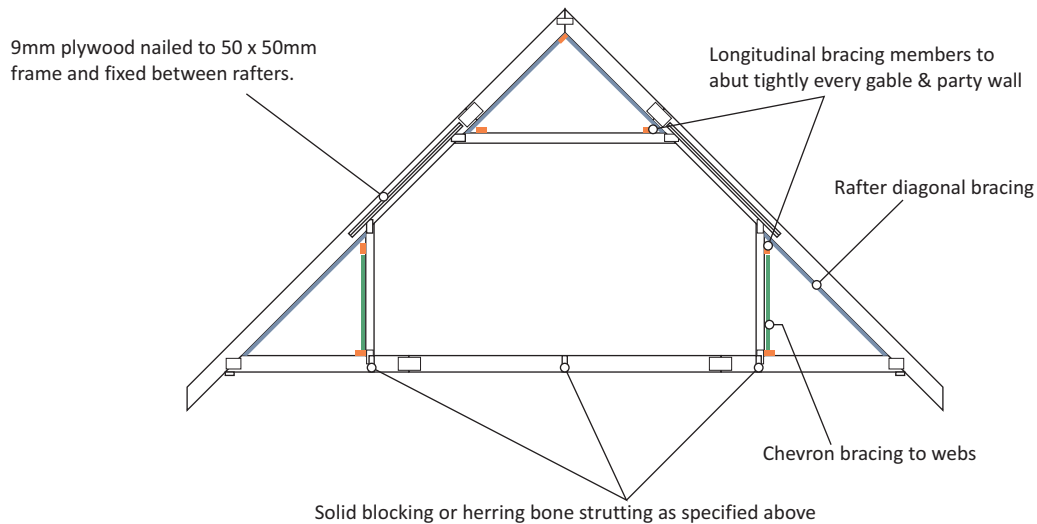

**Section A - A**

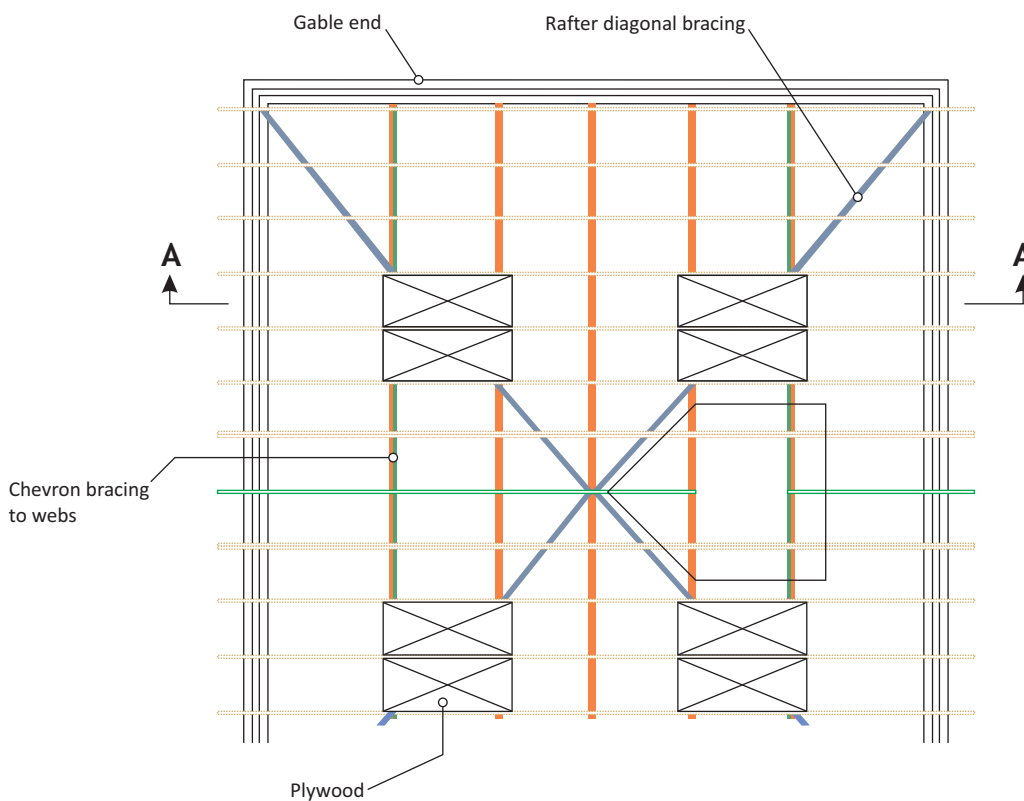

Before using this detail the Building Designer should satisfy themselves that it meets the requirements of all regulatory bodies concerned with the project.

# British Standard Bracing - Duo Pitch

## Section A - A

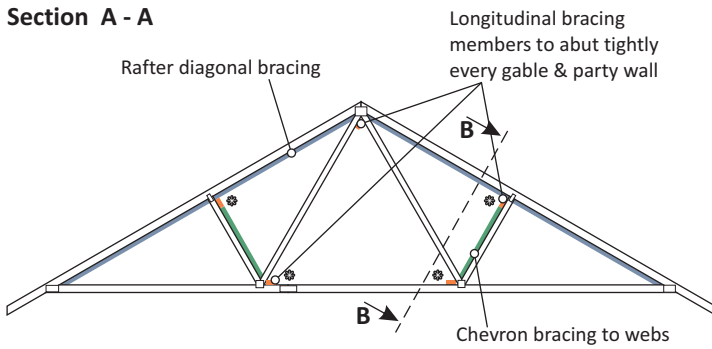

## Part view on arrow C

Rafter diagonal brace lap-jointed if required  
Ideally 45deg but not less than 35° nor greater than 55°

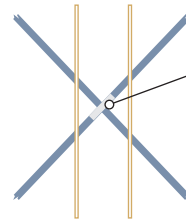
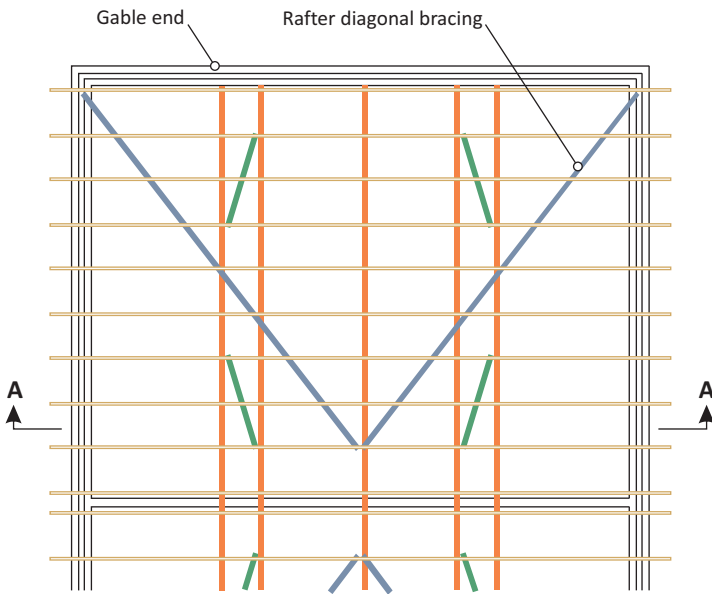
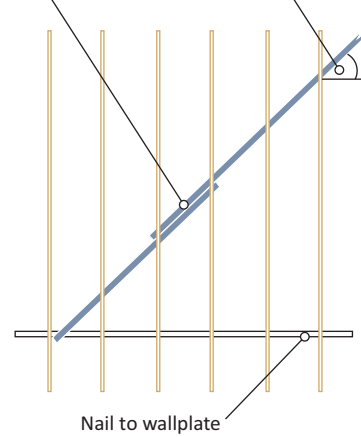

## Detail D

600mm long timber splice plate same size as bracing timbers. Fix using minimum of 4 No. 3.35 dia. galvanized nails each side x minimum nail length (equal to bracing thickness + 32mm).

## Section B - B

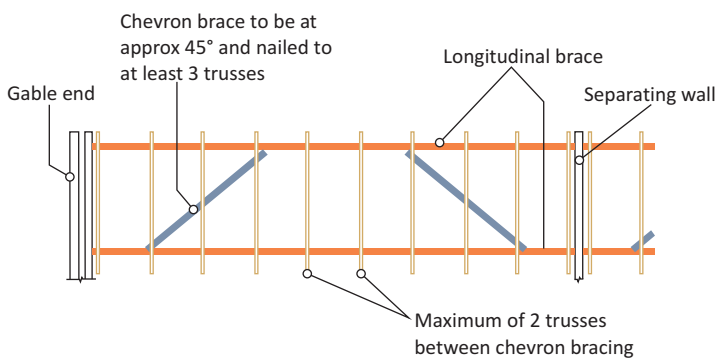

## Detail D

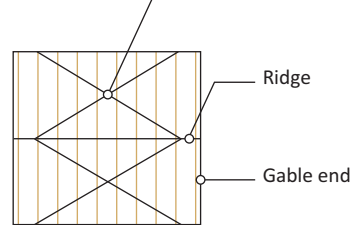

Plan of rafter diagonal bracing layout (narrower fronted detached roof)

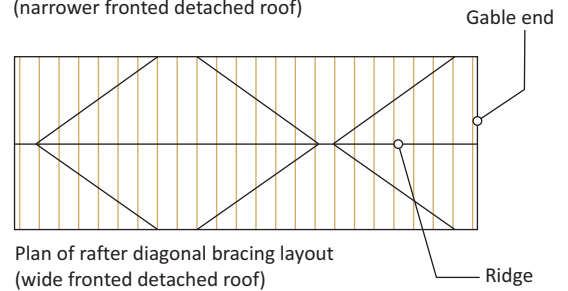

Plan of rafter diagonal bracing layout (wide fronted detached roof)

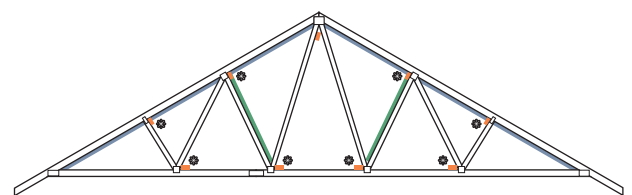
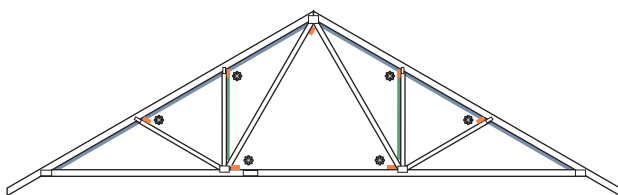

Note 1: Chevron bracing shown **█** is not required on internal members of truss for spans of 8m or less.

Note 2: \* denotes longitudinal bracing not required when the criteria described in item I(2) of Appendix A of BS5268 Pt.3 are met.

# British Standard Bracing - Mono Pitch

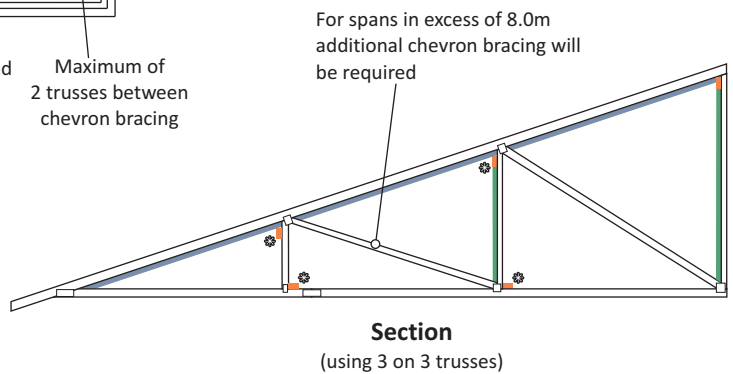
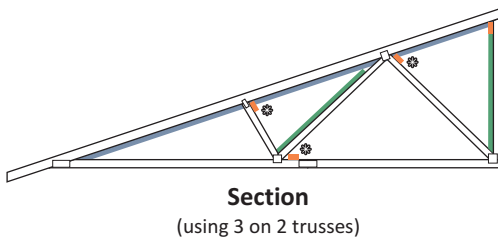
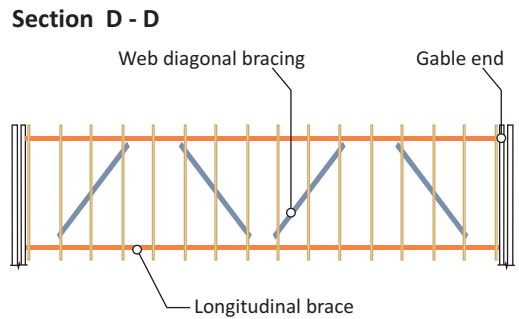
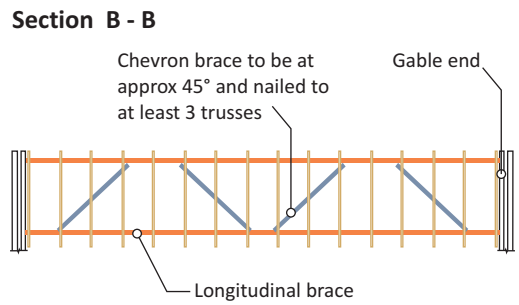
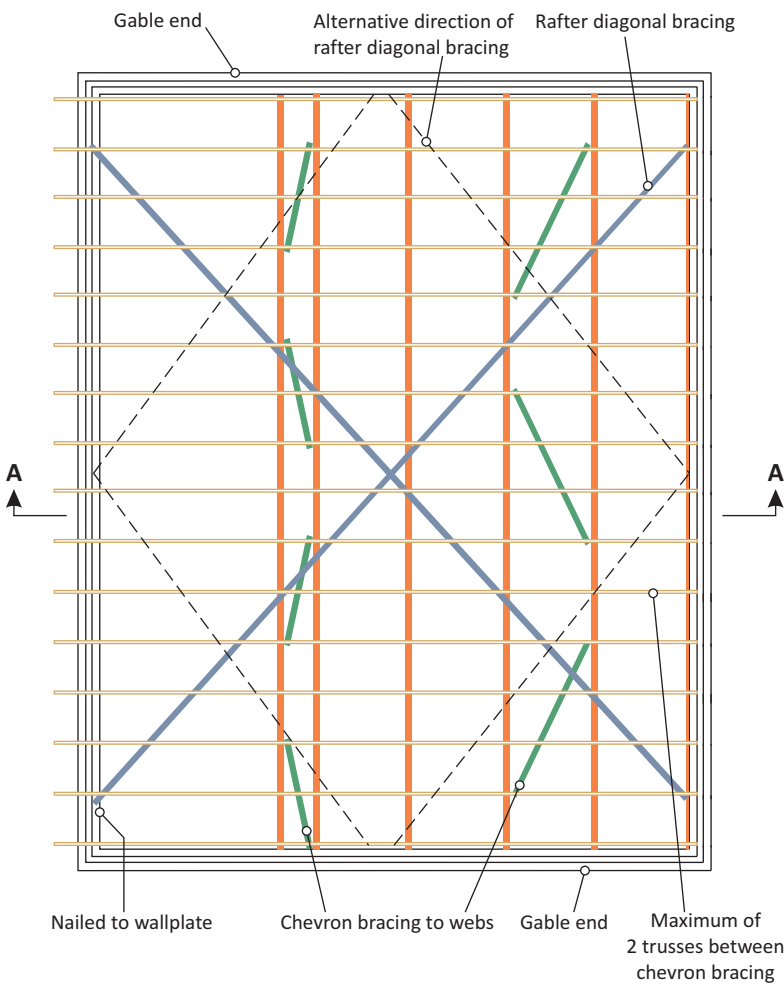
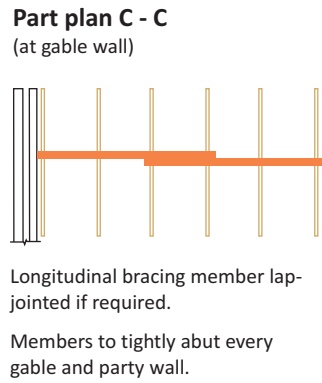
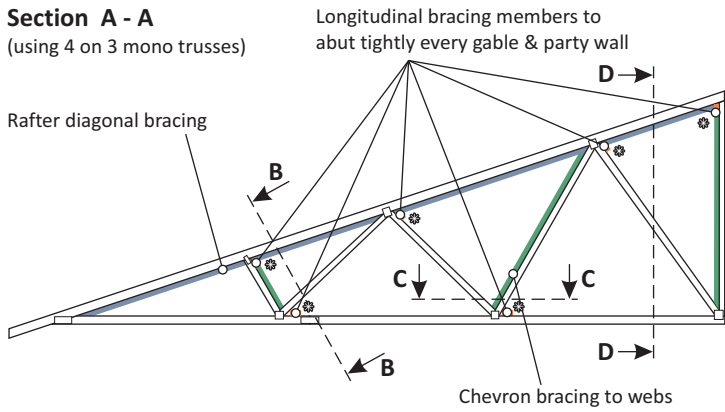

Note 1: Chevron bracing shown █ is not required on internal members of truss for spans of 8m or less.

Note 2: ⊛ denotes longitudinal bracing not required when the criteria described in item I(2) of Appendix A of BS5268 Pt.3 are met.

# Water Tank Support Details

## Tank stand

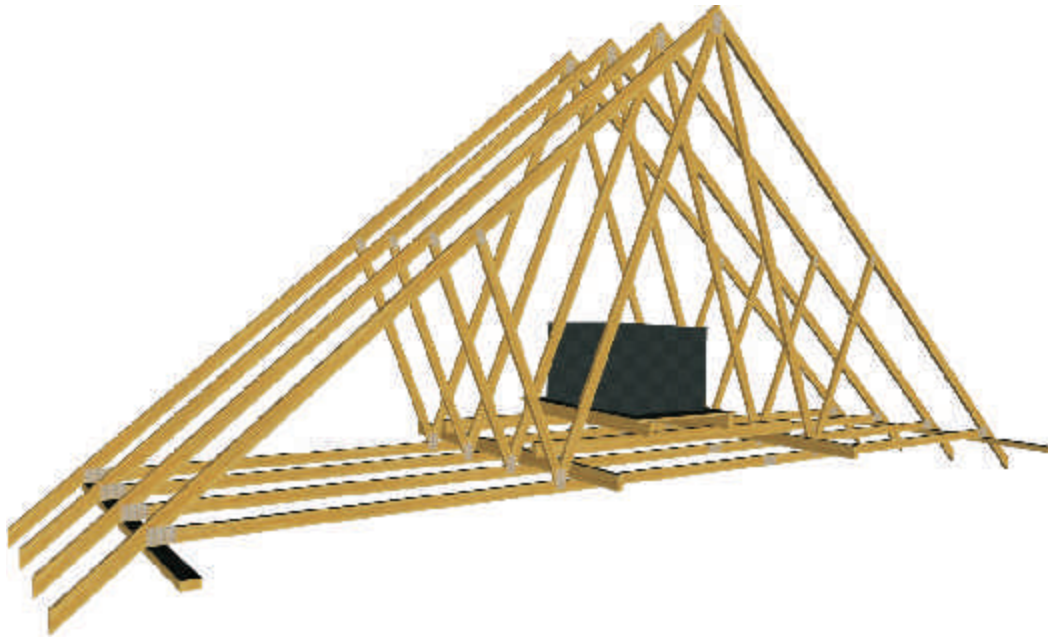

### Detail A

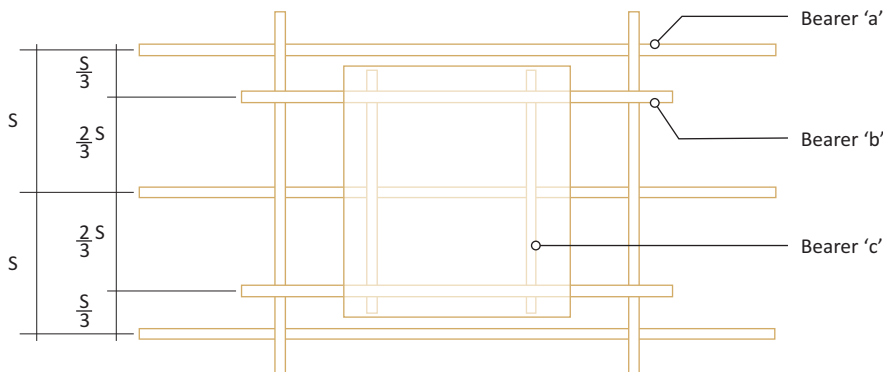

S = Trussed rafter spacing

### SIZES FOR SUPPORT MEMBERS

Tank capacity to marked waterline	Minimum member size (mm) a and c	b	Max. trussed rafter span for fink (m)	Max. bay size for other configurations (m)
Detail A not more than 300 litres on 4 trussed rafters	47 x 72	2/35 x 97 or 1/47 x 120	6.50	2.20
	47 x 72	2/35 x 120 or 1/47 x 145	9.00	2.80
	47 x 72	2/35 x 145	12.00	3.80
Detail B not more than 230 litres on 3 trussed rafters	47 x 72	1/47 x 97	6.50	2.20
	47 x 72	2/35 x 97 or 1/47 x 120	9.00	2.80
	47 x 72	2/35 x 120 or 1/47 x 145	12.00	3.80

Note: The timber used should be of strength class C16 or better as specified in BS5268 part 2.

# Glossary of Terms

**Apex/Peak**

The uppermost point of a truss.

**Attic truss/room-in-the-roof.**

A truss which forms the top storey of a dwelling but allows the area to be habitable by leaving it free of internal WEB members. This will be compensated by larger timber sizes elsewhere.

**Bargeboard**

Board fitted to conceal roof timbers at GABLE END.

**Battens**

Small timber members spanning over trusses to support tiles, slates etc.

**Bearer**

A member designed to distribute loads over a number of trusses.

**Bearing**

The part of a truss receiving structural support. This is usually a WALLPLATE but can be an internal wall etc.

**Binder**

A longitudinal member nailed to trusses to restrain and maintain correct spacing.

**Birdsmouth**

A notch in the underside of a RAFTER to allow a horizontal seating at the point of support (usually used with RAISED TIE TRUSSES).

**Blocking**

Short timbers fixed between chords to laterally restrain them. They should be at least 70% of the depth of the CHORDS.

**Bottom chord/Ceiling Tie**

The lowest member of a truss, usually horizontal which carries the ceiling construction, storage loads and water tank.

**Bracing**

This can be Temporary, Stability or Wind Bracing which are described under these headings.

**Building Designer**

The person responsible for the structural stability and integrity of the building as a whole.

**Cantilever**

The part of a structural member of TRUSS which extends beyond its bearing.

**Chevron Bracing**

Diagonal bracing nailed to the truss in the plane of the specified webs to add stability.

**Dead Load**

The load produced by the fabric of the building, always long term (see DESIGN LOADS).

**Deflection**

The deformation caused by the loads

**Design Loads**

The loads for which the unit is designed. These consider the duration of the loads long term, medium term, short term and very short term.

**Duo/dual pitch truss**

A truss with two rafters meeting at the APEX but not necessarily having the same PITCH on both sides.

**Eaves**

The line where the rafter meets the wall.

**Extended Rafter.**

See RAISED TIE TRUSS.

**Fascia**

Horizontal board fitted along the length of the building to the edge of the truss overhangs.

**Fink Truss**

The most common type of truss used for dwellings. It is duo-pitch, the rafter having the same pitch. The webs form a letter W.

**Gable End**

The end wall which is parallel to the trusses and which extends upwards vertically to the rafters.

**Hip End**

An alternative to a GABLE END where the end wall finishes at the same height as the adjacent walls. The roof inclines from the end wall, usually (but not always) at the same PITCH as the main trusses.

**Hip Set**

The trusses, girders and loose timbers required to form a hip end.

**Horn/nib**

An extension of the ceiling tie of a truss (usually monos or bobtailed trusses) which is built into

**Imposed Load**

The load produced by occupancy and use including storage, inhabitants, moveable partitions and snow but not wind. Can be long, medium or short term.

**Internal Member**

See WEB.

**Intersection**

The area where roofs meet.

**Jack Rafter**

An infill rafter completing the roof surface in areas such as corners of HIP ENDS or around chimneys.

**Live Load**

Term sometimes used for IMPOSED LOADS.

**Longitudinal Bracing.**

Component of STABILITY BRACING.

**Loose Timber**

Timbers not part of a truss but added to form the roof in areas where trusses cannot be used.

**Mono-pitch truss.**

A truss in the form of a right-angled triangle with a single rafter.

**Nailplate**

Metal PLATE having integral teeth punched from the plate material. It is used for joining timber in one plane with no overlap. It will have an accreditation certificate and will be manufactured, usually, from galvanised steel. It is also available in stainless steel.

**Node**

Point on a truss where the members intersect.

**Noggings**

Timber pieces fitted at right angles between the rafters and ceiling ties to form fixing points.

**Overhang**

The extension of a rafter or ceiling tie of a truss beyond its support or bearing

**Part Profile**

A truss type formed by truncating a normal triangular truss.

**Pitch**

The angle of the rafter to the horizontal, measured in degrees.

**Purlins**

Timber members spanning over trusses to support cladding or between trusses to support loose timbers.

**Queen**

Internal member (WEB) which connects the APEX to a third point on a FINK TRUSS.

**Rafter/Top chord**

The uppermost member of a truss which normally carries the roof covering.

**Rafter Diagonal Bracing**

Component of STABILITY BRACING.

**Raised Tie Truss**

A truss which is supported at a point on the rafter which is beyond the point where the rafter meets the ceiling tie.

**Return Span**

The span of a truss being supported by a girder.

**Ridge**

The line formed by the truss apexes.

**Roof Designer**

The person responsible for the roof structure as a whole and who takes into account its stability and capability of transmitting wind forces on the roof to suitable load-bearing walls.

**Scab**

Additional timber fitted to the side of a truss to effect a local reinforcement, particularly in RAISED TIE TRUSSES.

**Setting out Point**

The point on a truss where the undersides of the rafter and ceiling tie meet.

**Soffit**

Board fixed underneath EAVES overhang along the length of the building to conceal timbers.

**Span**

Span over wallplates is the distance between the outside edges of the two supporting wallplates. This is usually the overall length of the ceiling tie.

**Spandrel Panel**

A timber frame, triangular panel forming gable wall above ceiling line.

**Splice**

A joint between two members in line using a NAILPLATE or glued finger joint.

**Strap**

Metal component designed to fix trusses and wallplates to walls.

**Strut**

Internal member connecting the third point and the quarter point on a FINK TRUSS.

**Stub End**

See PART PROFILE.

**Temporary Bracing**

An arrangement of diagonal loose timbers installed for safety during erection. Often incorporated with permanent STABILITY and WIND BRACING structures.

**Timber Stress Grading**

The classification of timber into different structural qualities based on strength (see BS4978: 1996).

**Trimmer**

A piece of timber used to frame around openings.

**Trussed Rafter Designer**

The person responsible for the design of the TRUSSED RAFTER as a component and for specifying the points where Bracing is required.

**Truss clip**

A metal component designed to provide a safe structural connection of trusses to wallplates. Also to resist wind uplift and to remove the damage caused by SKEW NAILING.

**Truss Shoe**

A metal component designed to provide a structural connection and support for a truss to a girder or beam.

**Uniformly distributed load (UDL)**

A load that is uniformly spread over the full length of the member.

**Valley Board**

A member raking from incoming RIDGE to corner in a valley construction.

**Valley Frames/Set**

Infill frames used to continue the roofline when roofs intersect.

**Verge**

The line where the trussed rafters meet the gable wall.

**Wallplate**

A timber member laid along the length of the load bearing walls to support the trusses.

**Webs**

Timber members that connect the rafters and the ceiling tie together forming triangular patterns which transmit the forces between them.

**Wind bracing**

An arrangement of additional timbers or other structural elements in the roof space, specially designed to transmit wind forces to suitable load-bearing walls.

# ITWALPINE

Threemilestone, Truro, Cornwall, TR4 9LD  
technical enquiries : 01872 245456  
general enquiries : 01872 245450  
facsimile : 01872 245451  
[www.itwalpine.co.uk](http://www.itwalpine.co.uk)

**A division of ITW Limited.**

Registered Office: ITW Limited, Admiral House, St Leonard's Rd, Windsor, Berkshire. SL4 3BL  
Registered in England No. 559693

**© ITW Alpine 2008**

No part of this publication may be reproduced without prior permission from ITW Alpine.  
Last updated 04-04-08

**Disclaimer Notice**

All descriptions and illustrations in this technical manual are intended for guidance only and shall not constitute a "sale by description". All dimensions given are nominal and ITW Alpine may change the information, products and specifications from time to time for a variety of reasons, without prior notice. This information in this technical manual is provided "as is" at the date specified above. Updates will not be issued automatically. This information is not intended to have any legal effect, whether by way of advice, representation or warranty (express or implied). ITW Alpine accepts no liability whatsoever (to the extent permitted by law) if you place any reliance on this technical manual and you must do so at your own risk.

APPROVED DEALER:

